

**NEW**  
V 4000



Product Information

**V 4000 Press Brake System**  
Sensor for safeguarding  
press brakes



**SICK**

# The V 4000 Press Brake System

## Safety Principle

- Protective volume -  
Width: 1.6 in (40 mm)  
Height: 1.0 in (26 mm)  
Depth: scanning range
- Scanning range 0...24.6 ft (0...7.5 m)
- Object resolution better than 0.6 in (14 mm)
- High immunity against vibrations and misalignments

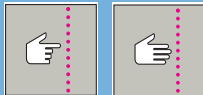

pending

The V 4000 Press Brake System is a camera-based system for complete safeguarding of press brakes. It is an all-inclusive sensor and evaluation system, consisting of a sender and a receiver mounted on the upper beam of the press, which safeguards the punch during the fast downward movement. It creates a safety volume below the punch line and its Output Signal Switching Devices (OSSDs) provide a signal to the press controller to stop the closing movement of the press as soon as an object (such as a hand or finger) is detected.

The press brake monitoring system is easy to configure because it uses existing linear scales to calculate machine-relevant information, such as the upper beam's position, velocity, direction and stopping distance. The V 4000 can also be easily integrated into the machine's human-machine interface (HMI).

The V 4000 complies with Type 4 according to IEC 61496-1 and 2, SIL 3 according to IEC 61508 and is suitable for controls with Safety Category 4 according to EN 954-1.

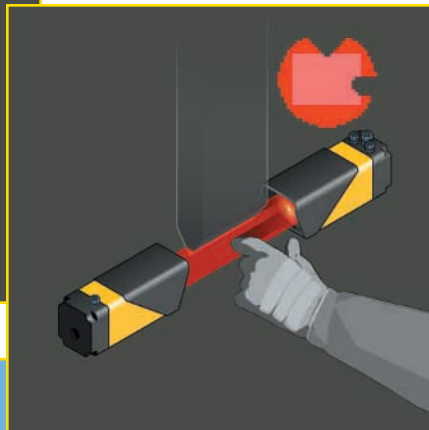
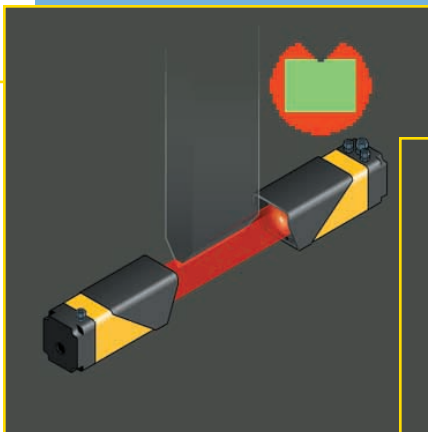

- The V 4000 monitors a safety volume directly below the punch
- Any infringements of the safety volume generate a two-channel signal to stop the machine. The V 4000 resolution is better than 14 mm.

# Maximum throughput...

### Production Manager

- Simple to operate, non-intrusive safety implementation
- Supports complex bends
- Self teaching modes make it very simple to change materials without realignment
- Minimizes machine stress by minimizing hard stops
- Foot pedal interface frees operator hands
- Maximum range and maximum speed
- Maximum production by optimizing machine speed

### Machine Operator

- Maximum safety for finger and hand protection
- Most sophisticated system for press brake safeguarding in the market
- Type 4, SIL 3 device
- Resolution better than 14 mm
- Interruption-free bending cycles
- Easy to configure and align
- Intuitive to use
- Self teaching device
- Multiple bending modes
- Visualization and diagnostic tools

# without compromising...

### Machine Builder

- Camera-based technology that monitor entire safety volume
- Cost effective, all-inclusive safety solution
- Support for complex bending modes
- Easy to install and configure
- Full integration with machine HMI possible
- Minimizes machine stress by minimizing hard stops
- Worldwide installation, troubleshooting and repair support
- SICK installation services available
- Retrofit opportunity

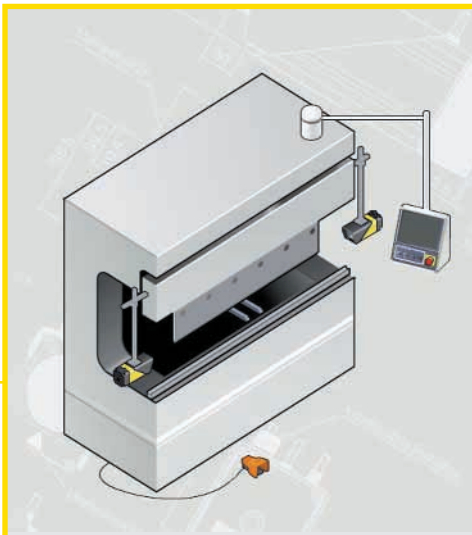

# safety.

## V 4000 Applications

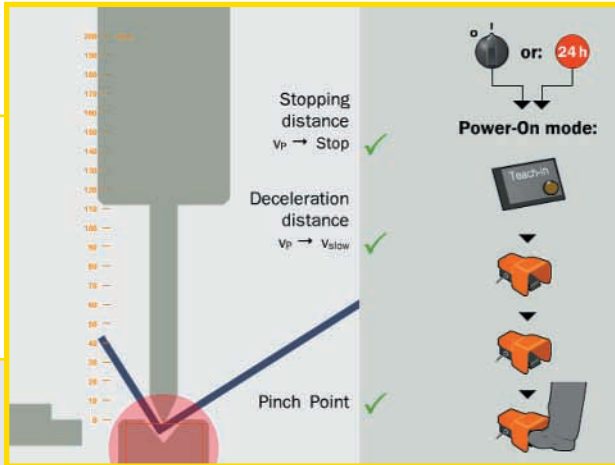

### Power-On Mode

Upon start-up of the machine or every 24 hours, the V 4000 Press Brake System gathers machine performance information: stopping distance, the deceleration distance and pinch point.

### Bending in Standard Mode

Standard mode is used for bending flat pieces of metal. The V 4000 monitors infringements from the sides, top and bottom.

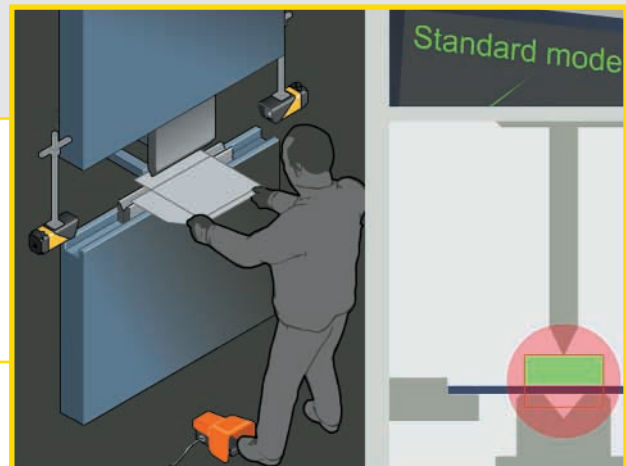

As the V 4000 travels with the punch, it monitors the entire safety volume for infringements. The system mutes 6 mm above the pinch point to allow bending.

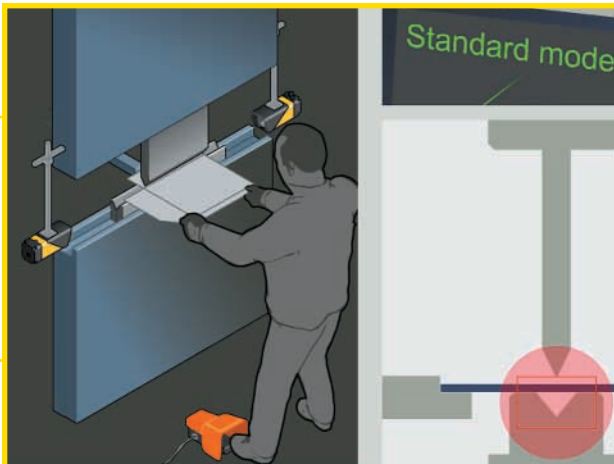

## V 4000 Box & Back Gauge Modes

### *Bending in Box Mode*

Box mode is used for bending metal with flanges. The V 4000 provides complete safety while accommodating for the box presence in the safety volume.

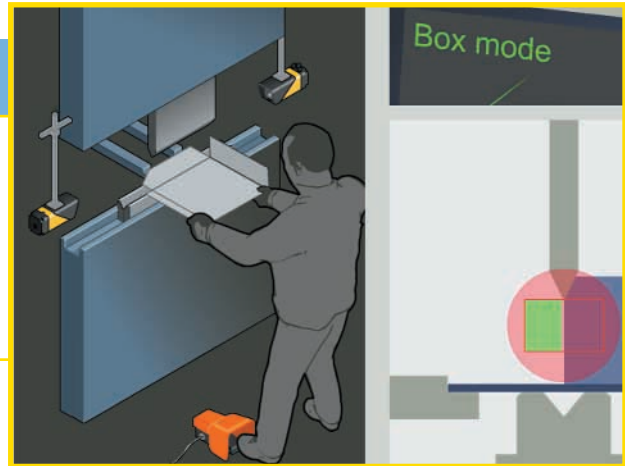

As the V 4000 travels with the punch, it monitors the safety volume opposite the box, where an infringement could occur. The system mutes 6 mm above the pinch point to allow bending.

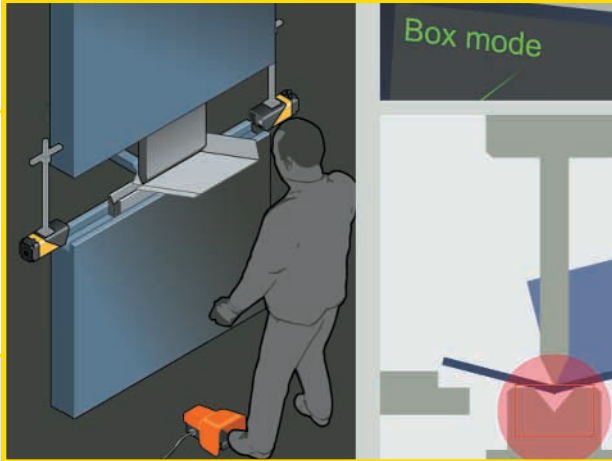

### *Bending in Back Gauge (Back Stop) Mode*

Back Gauge mode is used in bending metal with flanges requiring a back gauge. The V 4000 provides complete safety while accommodating for the box and back gauge presence in the safety volume.

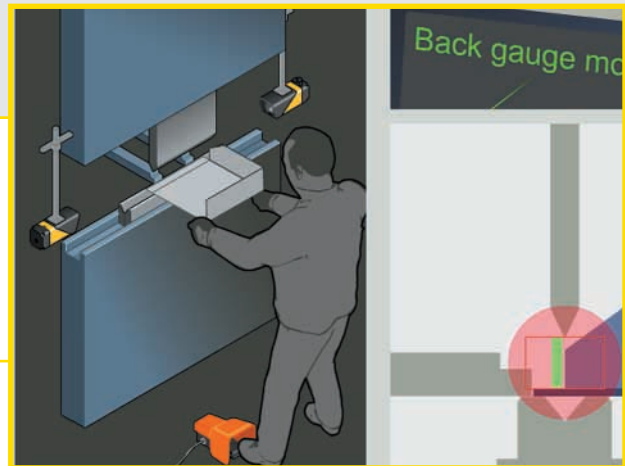

As the V 4000 travels with the punch, it monitors the safety volume between the box and the back gauge, where an infringement could occur. The system mutes 6 mm above the pinch point to allow bending.

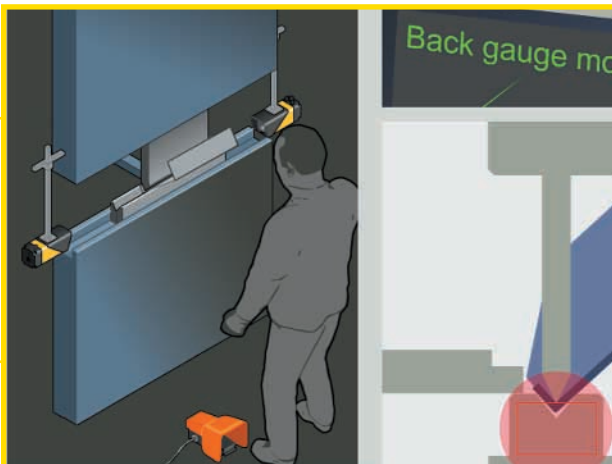

# V 4000 Ordering Information

## Ordering information notes

### Minimum Requirements:

- Sender/Receiver units required for all installations plus one of the following installation kits.
- Installation Kit # 1 includes alignment plates and necessary cables. Mounting arms to be provided by machine builder or integrator
- Installation Kit # 2 includes alignment plates, mounting arms and all necessary cables. Suited for retrofit applications. Installation Kit # 2 includes Installation Kit # 1

In addition, all V 4000 Press Brake System installations require encoder signal for monitoring ram movement. To gain encoder signal:

- For machines with operating encoders meeting V 4000 Press Brake System requirements use the V 4000 PBI kit for interfacing with encoder
- In all other cases, a new encoder installation is recommended. See V 4000 Press Brake System Operating Instructions Section 10.1.3 for encoder performance requirements.

## Ordering data

V40PBP-0700000	■ V 4000 sender/receiver pair	7 029 773
-V40PBS-0700000	■ V 4000 sender	1 025 765
-V40PBE-0700000	■ V 4000 receiver	1 025 766

## Ordering information accessories

### Accessories

Designation	Description	Part Number
<b>V 4000 Installation Kit #1:</b>	■ Mounting kit 1 and cables	<b>7 029 770</b>
-V 4000 Mounting Kit 1	■ Alignment plate x 2	2 031 126
-V 40 Cable, 4 Cond	■ 15 meter sender to receiver cable	6 029 221
-V 40 Cable, 18 Cond per m	■ 10 meter	6 029 223
-Comm Cable, 8 m	■ Cable between PC and V 4000	2 027 649
<b>V 4000 Installation Kit #2:</b>	■ Mounting kits 1 and 2 and cables	<b>7 029 771</b>
-V 4000 Mounting Kit 1	■ Alignment plate x 2	2 031 126
-V 40 Cable, 4 Cond	■ 15 meter sender to receiver cable	6 029 221
-V 40 Cable, 18 Cond per m	■ 10 meter receiver cable	6 029 223
-V 4000 Mounting Kit 2	■ Retaining arm x 2	2 031 745
-Comm Cable, 8 m	■ Cable between PC and V 4000	2 027 649
<b>V 4000 PBI Kit</b>	■ PBI and cable to receiver	<b>7 029 772</b>
-V 4000 PBI	■ Press brake interface	1 026 798
-V 40 Cable, 4 Cond	■ 10 meter cable from PBI to receiver	6 029 222
Spare Part Connector PBI	■ 2 pieces ■ Including pull-out tool	2 032 052
Alignment Mask Kit	■ Masks for receiver, sender and punch	2 030 829
Test Piece	■ Test piece for testing protection field	4 040 724
Magnetic Plate	■ For covering open v-groove of die under workpiece	4 040 736

### Connection

Designation	Description	Part Number
Power Supply	■ 24 V DC, 2.1 A	7 028 789

## Detailed technical data

→ Further data can be found in the operating instructions

### General system data

Laser class	Laser class 1M (21 CFR 1040.10 and 1040.11, IEC 60825-1:2001)
Scanning range	0...24.6 ft (0...7.5 m)
Cross-section safety volume	1.6 x 1.0 in (40 x 26 mm)
Object resolution	
-Minimum	0.4 in (10 mm)
-Maximum	0.5 in (14 mm)
Protection class according to DIN VDE 0106, DIN EN 50178	III
Enclosure rating (IEC 60 529)	IP 54
Supply voltage $U_V$ at device <sup>1)</sup>	24 V (19.2...28.8 V)
Synchronization	Electrical
Type according to IEC 61 496	Type 4
Type according to IEC 61 508	SIL 3

### Sender

Power consumption	Max. 0.2 A
-------------------	------------

### Receiver

Output signal switching devices (OSSD)	2 PNP semiconductors, short-circuit protected <sup>2)</sup> , cross-circuit monitored
-Response time T1	10 ms
-Switching voltage HIGH (active, $U_{eff}$ )	24 V ( $U_V - 2.7 V \dots U_V$ )
-Switching voltage LOW (inactive)	0 V (0...3.5 V)
-Switching current	0...500 mA
Power Consumption	Max. 0.5 A (without OSSD)
Application diagnostic output for "teach in" and "target speed" $V_{slow}$	PNP semiconductors, short-circuit protected <sup>2)</sup>
-Switching voltage HIGH (active)	24 V ( $U_V - 3.3 V \dots U_V$ )
-Switching voltage LOW (inactive)	High resistance
-Switching current	0...200 mA

### Operating data

Connection	Plug-in connection housing with screw terminal connections
Cable length <sup>3)</sup>	Max. 98.4 ft (30 m)
Cable cross-section	Min. 0.006 in <sup>2</sup> (0.14 mm <sup>2</sup> )
Ambient operating temperature	32...122°F (0...50°C)
Air humidity (non-dewing)	15...95%
Storage temperature	-13...158°F (-25...70°C) (max. 24 h)
Rigidity	5 g, 10...100 Hz in compliance with IEC 61496-1 section 5.1.2 and 5.4.2
Shock resistance	
-Individual shock	15 g, 11 ms in compliance with EN 60068-2-27
-Repetitive shock	10 g, 16 ms in compliance with IEC 61496-1 section 5.1.2 and 5.4.4.2

1) The external voltage supply must be capable of buffering brief mains voltage failures of 20 ms as specified in EN 60 204-1. Suitable power supplies are available as accessories from SICK (Siemens type series 6 EP 1)

2) Applies to the voltage range between -30 V and 30 V

3) Depending on load, power supply and cable cross-section. The technical specifications must be observed.



SICK is one of the world's leading manufacturers of safety systems, sensors, and automatic identification products for industrial applications. SICK holds more than 350 patents for its innovative products. Through its Industrial Sensors, Safety Systems, Automatic Identification, and Environmental and Process Analysis divisions, the company has operations in 65 countries. SICK North America is headquartered in Minneapolis, MN.



Products from SICK provide comprehensive safeguarding of both workers and machinery. As specialists in sensor technology, SICK develops and manufactures pioneering products that provide protection in hazardous zones, dangerous locations and for safeguarding access points. By providing services, which encompass all aspects of machine safety and security, SICK is setting new standards in safety technology.



Our wide range of sensors provides solutions to suit any application in the field of automation. Even under rugged ambient conditions, objects are reliably detected, counted and positioned regardless of their form, location and surface finish.



Whether the tasks involve identification, handling, classification or volume measurement, innovative automatic identification systems and laser measuring systems from SICK function reliably, even under rapid cycle times. Products from SICK conform to the latest standards and can be easily integrated in all industrial environments and external applications.

**Australia**

Phone +61 3 94 97 41 00  
0 08 33 48 02 – toll free  
Fax +61 3 94 97 11 87

**Austria**

Phone +43 22 36 62 28 80  
Fax +43 22 36 62 28 85

**Belgium/Luxembourg**

Phone +32 24 66 55 66  
Fax +32 24 63 35 07

**Brazil**

Phone +55 11 55 61 26 83  
Fax +55 11 55 35 41 53

**China**

Phone +852 27 63 69 66  
Fax +852 27 63 63 11

**Czech Republic**

Phone +42 02 57 81 05 61  
Fax +42 02 57 81 05 59

**Denmark**

Phone +45 45 82 64 00  
Fax +45 45 82 64 01

**Finland**

Phone +358 9 72 85 00  
Fax +358 9 72 88 50 55

**France**

Phone +33 1 64 62 35 00  
Fax +33 1 64 62 35 77

**Germany**

Phone +49 21 15 30 10  
Fax +49 21 15 30 11 00

**Great Britain**

Phone +44 17 27 83 11 21  
Fax +44 17 27 85 67 67

**Italy**

Phone +39 02 92 14 20 62  
Fax +39 02 92 14 20 67

**Japan**

Phone +81 3 33 58 13 41  
Fax +81 3 33 58 05 86

**Korea**

Phone +82 2 786 63 21-4  
Fax +82 2 786 63 25

**Netherlands**

Phone +31 3 02 29 25 44  
Fax +31 3 02 29 39 94

**Norway**

Phone +47 67 56 75 00  
Fax +47 67 56 61 00

**Poland**

Phone +48 2 28 37 40 50  
Fax +48 2 28 37 43 88

**Singapore**

Phone +65 67 44 37 32  
Fax +65 68 41 77 47

**Spain**

Phone +34 9 34 80 31 00  
Fax +34 9 34 73 44 69

**Sweden**

Phone +46 86 80 64 50  
Fax +46 87 10 18 75

**Switzerland**

Phone +41 4 16 19 29 39  
Fax +41 4 16 19 29 21

**Taiwan**

Phone +886 2 23 65 62 92  
Fax +886 2 23 68 73 97

**USA/Canada/Mexico**

Phone +1 (952) 9 41 67 80  
Fax +1 (952) 9 41 92 87

Branch offices and representatives  
in all major industrial countries.

# SICK

6900 West 110th Street • Minneapolis, MN 55438 USA  
Phone 800.325.SICK (7425) • Fax 952.941.9287 • www.sickusa.com