

MX BAND CYLINDER

ENDURANCE TECHNOLOGYSM

[N] INTERNAL BEARING

[S] SOLID BEARING

[P] PROFILED RAIL



MAXIMUM DURABILITY

INTRODUCING THE MX BAND CYLINDER – DESIGNED TO OUTLAST EVERY RODLESS CYLINDER ON THE MARKET

The MX pneumatic rodless cylinder is exactly what you expect from the industry's number one rodless supplier. Designed with our exclusive ENDURANCE TECHNOLOGYSM features, the MX delivers superior performance to meet the most demanding applications. Nobody knows rodless like Tolomatic, and the MX proves it.

- **DURABLE BEARINGS.** Three bearing choices to match your application needs. Profiled rail design uses THK[®] Caged Ball[®] technology to reduce friction and extend actuator life. Solid bearing design reduces stress concentration by 59% for optimum performance. Internal bearing design is permanently lubricated for long, trouble-free service.
- **DURABLE BANDS.** Stainless steel bands are stronger and will not elongate like elastomer (non-metallic) bands, providing reliable sealing over the life of the actuator.



N-INTERNAL BEARING

- Low cost solution for applications with limited load and bending moment requirements
- Lowest breakaway pressure
- Best in many vertical applications
- Permanently lubed internal bearing

S-SOLID BEARING

- Increased Mx moment capacity
- Large bearing surface contact area minimizes pressure on bearing surfaces for long service life
- Large carrier mounting pattern for more load stability and compatibility with existing BC2 applications
- Engineered bearing material does not require additional lubrication
- Solid bearings are field replaceable

P-PROFILED RAIL

- THK[®] Caged Ball[®] bearings with reduced friction for reliable service life
- High load and bending moment capacities
- Low profile to fit your application
- High precision bearings feature smooth, low breakaway motion



SELECT THE PERFORMANCE YOU NEED

Choose from: • Three Bearing Models • Three Bore Sizes (six by the end of 2007) • Built to Your Specified Stroke Length!

MOMENT & LOAD CAPACITY COMPARISON

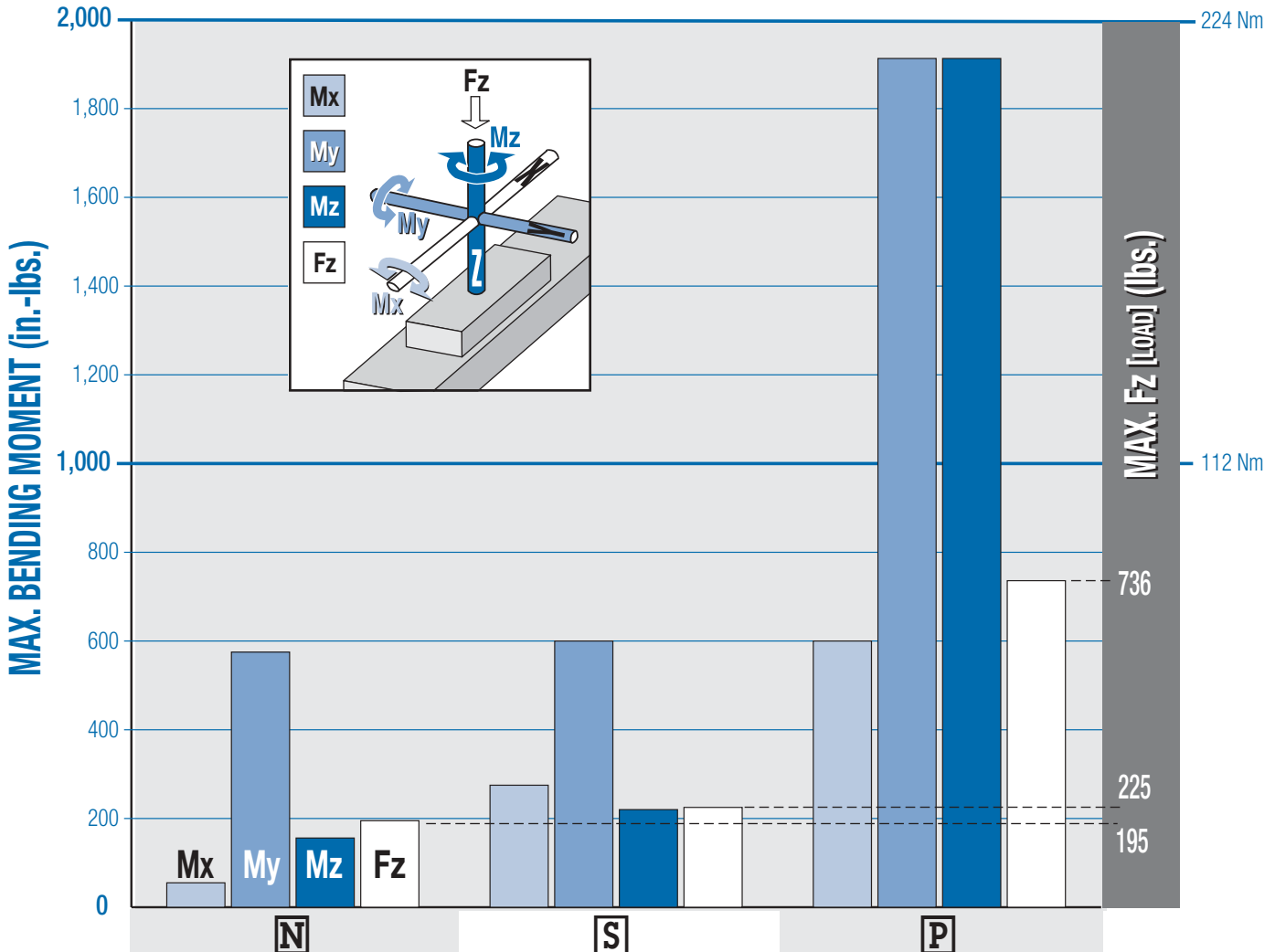
Graph for model comparison, data from MXP40, 38mm (1.5") bore

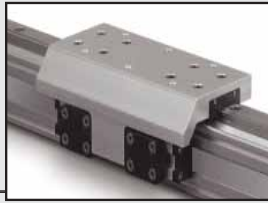

Tolomatic MX Band Cylinder Model	N	S	P
			
Bearing Type	Internal Bearing	Solid Bearing	Profiled Rail
Moment Capacity	Moderate	Moderate + Mx	High
Isolated Piston	No	Yes	Yes
Ideal Applications	<ul style="list-style-type: none"> • Guided Loads • Vertical Orientation • Impact Loads 	<ul style="list-style-type: none"> • Side Loads • Impact Loads 	<ul style="list-style-type: none"> • High Moment Loads • High Speeds with Heavy Loads • High Precision
Product Details	Page 4	Page 6	Page 8

N INTERNAL BEARING

ENDURANCE TECHNOLOGYSM

STAINLESS STEEL BANDS

- Both interior sealing band and exterior dust band made of fatigue resistant stainless steel

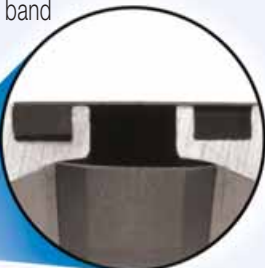

STAINLESS STEEL IS DURABLE, FLEXIBLE AND CORROSION FREE



- Does not stretch like bands made of rubber or polymer materials
- Stainless steel sealing bands resist blow out during pressure spikes that may occur during high velocity cushioning

RETAINED DUST BAND

- Retained dust band keeps contaminants from entering the cylinder interior, protecting components for reduced maintenance and increased uptime

INTERNAL BEARINGS

- Design maximizes piston bearing surface area for less pressure on bearing surfaces, less pressure results in less wear
- Permanent lubrication for low friction and extended bearing life
- Internal location provides protection from external contaminants, extending life

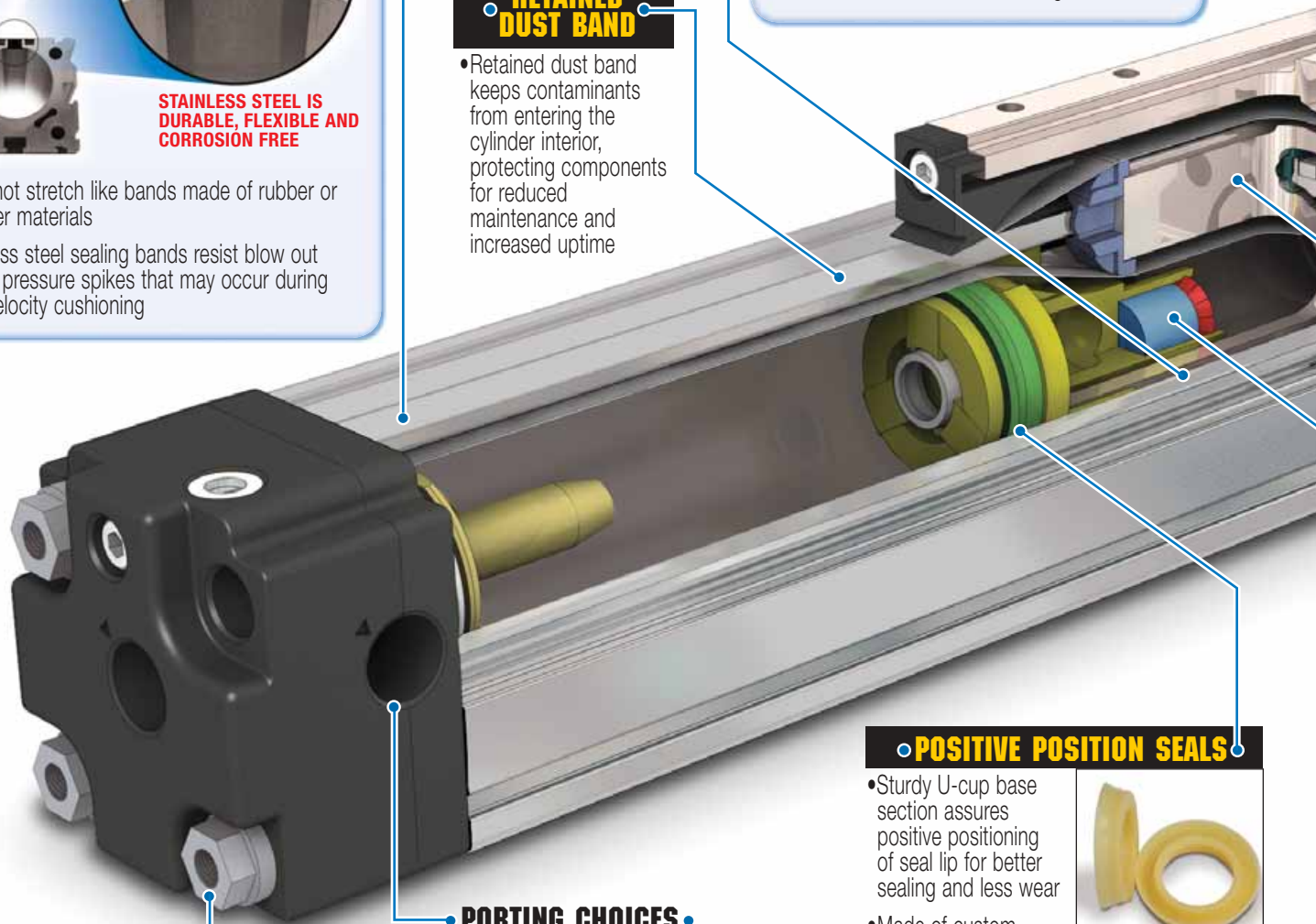

DIRECT MOUNT

- Head bolts are tapped for direct mounting

INCH OR METRIC MOUNTING

- Your choice of inch (*US standard*) or metric fasteners for carrier and head bolt mounting

PORTING CHOICES

- 4-ported heads are standard to allow air connections on sides, end or bottom
- Single-end porting allows convenient one end air connection
- NPT, Metric Parallel (ISO-G/BSP) & Metric Taper (Rc/BST) available on both metric and inch (*US standard*) mount actuators

POSITIVE POSITION SEALS

- Sturdy U-cup base section assures positive positioning of seal lip for better sealing and less wear
- Made of custom formulated polyurethane for pliable, wear resistant seal lip



NON-WEAR BAND RETENTION

- Magnetically retained bands are not subject to wear as are mechanically retained systems
- Immediate band engagement and release results in less drag on piston for lower breakaway force during initial carrier movement

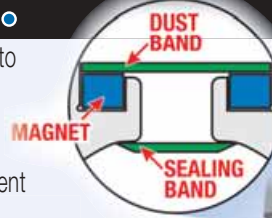

DUST WIPER

- Formed end cap and side dust wipers keep contaminants from entering the cylinder's internal area

ADJUSTABLE CUSHIONS

- Easy screw adjustment for smooth deceleration protecting actuator from high stress at end-of-stroke
- Adjustable cushions with retained stainless steel needle screw for increased safety

NOTE: Boxed letters indicate ordering codes

HIGH STRENGTH PISTON

- Single piece extrusion for piston bracket and carrier reduces failure points
- Piston bracket neck cross-sectional area is up to 28% greater than competitive designs, providing increased durability



25mm PISTON BRACKET
MINIMUM CROSS-SECTIONAL AREA (mm²)

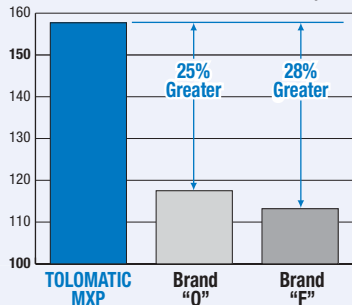

INTERNAL MAGNETS

- Standard feature that allows sensor installation on left, right or bottom of the extrusion

OPTIONS



AUXILIARY CARRIER **D****W**

- 2X higher Fz (load) capacity
- High bending moment capacity



FLOATING MOUNT **F****L**

- Compensates for non-parallelism between MX band cylinder and externally guided load



TUBE CLAMPS **T****C**

- Used for intermediate support
- Flush with bottom of actuator to retain low profile
- Drop-in, adjustable mounting locations



FOOT MOUNTS **F****M**

- For end mounting of MX band cylinder
- Use to bottom or side mount actuator



SHOCK ABSORBERS **A****H** **S****H**

- Allows increased operating speed and load
- Self-compensates for load or speed changes
- Minimizes impact load to equipment
- Fixed or adjustable position shocks



SINGLE-END PORTING **S**

- Convenient single-end air connection



SWITCHES

- Largest number of sensing choices in the industry: Reed, Solid State PNP or NPN, all available normally open or normally closed
- Flush mount, drop-in installation, anytime
- Bright LEDs, power & signal indication
- CE rated, RoHS compliant

S SOLID BEARING

ENDURANCE TECHNOLOGYSM

Endurance Technology features are designed for maximum durability to provide extended service life.

STAINLESS STEEL BANDS

- Both interior sealing band and exterior dust band made of fatigue resistant stainless steel



STAINLESS STEEL IS DURABLE, FLEXIBLE AND CORROSION FREE



- Does not stretch like bands made of rubber or polymer materials
- Stainless steel sealing bands resist blow out during pressure spikes that may occur during high velocity cushioning

RETAINED DUST BAND

- Retained dust band keeps contaminants from entering the cylinder interior, protecting components for reduced maintenance and increased uptime

POSITIVE POSITION SEALS

- Sturdy U-cup base section assures positive positioning of seal lip for better sealing and less seal wear
- Made of custom formulated polyurethane for pliable, wear resistant seal lip



INTERNAL MAGNETS

- Standard feature that allows sensor installation on left, right or bottom of the extrusion

ISOLATED PISTON

- Unique design isolates the piston from the applied load, extending the service life of the piston seals



- Piston remains isolated even when the carrier is deflected under load
- Piston bracket and carrier feature single piece extrusions, reducing failure points

PORTING CHOICES

- 4-ported heads are standard to allow air connections on sides, end or bottom
- Single-end porting allows convenient one end air connection
- NPT, Metric Parallel (ISO-G/BSP) & Metric Taper (Rc/BST) available on both metric and inch (US standard) mount actuators

DIRECT MOUNT

- Head bolts are tapped for direct mounting

INCH OR METRIC MOUNTING

- Your choice of inch (US standard) or metric fasteners for carrier and head bolt mounting

NON-WEAR BAND RETENTION

- Magnetically retained bands are not subject to wear as are mechanically retained systems
- Immediate band engagement and release results in less drag on piston for lower breakaway force during initial carrier movement

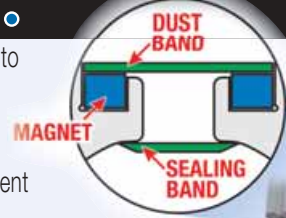

DUST WIPER

- Formed end cap and side dust wipers keep contaminants from entering the cylinder's internal area

ADJUSTABLE CUSHIONS

- Easy screw adjustment for smooth deceleration protecting actuator from high stress at end-of-stroke
- Adjustable cushions with retained stainless steel needle screw for increased safety

NOTE: Boxed letters indicate ordering codes

LARGE FLEXIBLE MOUNTING PATTERN

- Carrier gives more load stability
- Compatibility with existing BC2 applications
- More fastening options

NON-BINDING BEARING ARMS

- Bearings are tensioned indirectly, providing bind free adjustment

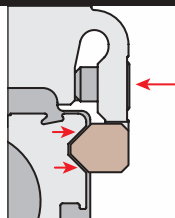

TRAPEZOIDAL BEARINGS

- Trapezoidal design maximizes bearing surface area for less pressure on bearing surfaces; less pressure results in less wear
- Engineered bearing material has low static and dynamic friction with low wear properties for long lasting, smooth operation
- Bearings are field replaceable for extended service life

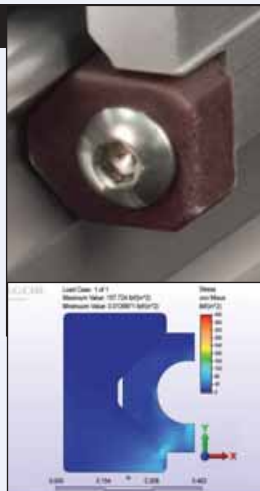

OPTIONS



AUXILIARY CARRIER DW

- 2X higher Fz (load) capacity
- High bending moment capacity



FLOATING MOUNT FL

- Compensates for non-parallelism between MX band cylinder and externally guided load



TUBE CLAMPS TC

- Used for intermediate support
- Flush with bottom of actuator to retain low profile
- Drop-in, adjustable mounting locations



FOOT MOUNTS FM

- For end mounting of MX band cylinder
- Use to bottom or side mount actuator



SHOCK ABSORBERS AH SH

- Allows increased operating speed and load
- Self-compensates for load or speed changes
- Minimizes impact load to equipment
- Fixed or adjustable position shocks



SINGLE-END PORTING S

- Convenient single-end air connection



SWITCHES

- Largest number of sensing choices in the industry: Reed, Solid State PNP or NPN, all available normally open or normally closed
- Flush mount, drop-in installation, anytime
- Bright LEDs, power & signal indication
- CE rated, RoHS compliant

P PROFILED RAIL

ENDURANCE TECHNOLOGYSM

Endurance Technology features are designed for maximum durability to provide extended service life.

CAGED BALL[®] BEARINGS

- THK[®] Caged Ball[®] bearings are used to reduce friction and extend actuator life
- Caged Ball[®] technology creates a grease pocket between ball elements, reducing friction, noise and maintenance
- Large permissible moment loads
- Low profile caged ball bearings
- High speed operation, low heat generation
- High precision, smooth, low friction motion

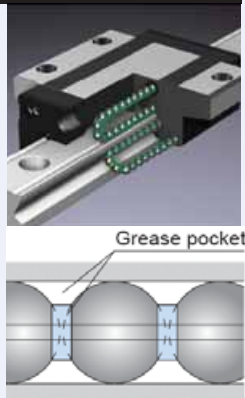

INTERNAL MAGNETS

- Standard feature that allows sensor installation anytime on the open side or bottom of the extrusion

POSITIVE POSITION SEALS

- Sturdy U-cup base section assures positive positioning of seal lip for better sealing and less seal wear
- Made of custom formulated polyurethane for pliable, wear resistant seal lip



STAINLESS STEEL BANDS

- Both interior sealing band and exterior dust band made of fatigue resistant stainless steel

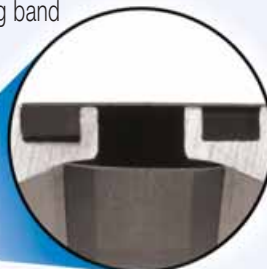

STAINLESS STEEL IS DURABLE, FLEXIBLE AND CORROSION FREE

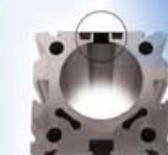

- Does not stretch like bands made of rubber or polymer materials
- Stainless steel sealing bands resist blow out during pressure spikes that may occur during high velocity cushioning

PORTING CHOICES

- 4-ported heads are standard to allow air connections on side, top or end
- Single-end porting allows convenient one end air connection
- NPT, Metric Parallel (ISO-G/BSP) & Metric Taper (Rc/BST) available on both metric and inch (US standard) mount actuators

DIRECT MOUNT

- Head bolts are tapped for direct mounting

INCH OR METRIC MOUNTING

- Your choice of inch (US standard) or metric fasteners for carrier and head bolt mounting

LOW CARRIER HEIGHT

- Reduces overall cylinder envelope
- Large mounting pattern for high load stability

ADJUSTABLE CUSHIONS

- Easy screw adjustment for smooth deceleration protecting actuator from high stress at end-of-stroke
- Adjustable cushions with retained stainless steel needle screw for increased safety

NON-WEAR BAND RETENTION

- Magnetically retained bands are not subject to wear as are mechanically retained systems
- Immediate band engagement and release results in less drag on piston for lower breakaway force during initial carrier movement

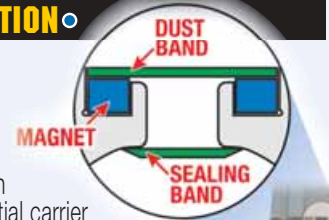

RETAINED DUST BAND

- Retained dust band keeps contaminants from entering the cylinder interior, protecting components for reduced maintenance and increased uptime

DUST WIPER

- Formed end cap and side dust wipers keep contaminants from entering the cylinder's internal area

ISOLATED PISTON

- Unique design isolates the piston from the applied load, extending the service life of the piston seals

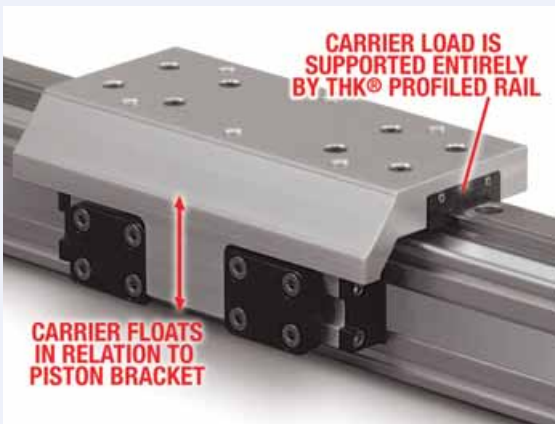

- Piston remains isolated even when the carrier is deflected under load
- Piston bracket and carrier feature single piece extrusions, reducing failure points

NOTE: Boxed letters indicate ordering codes

OPTIONS



AUXILIARY CARRIER **D****W**

- 2X higher Fz (load) capacity
- High bending moment capacity



TUBE CLAMPS **T****C**

- Used for intermediate support
- Flush with bottom of actuator to retain low profile
- Drop-in, adjustable mounting locations



FOOT MOUNTS **F****M**

- For end mounting of MX band cylinder
- Use to bottom or side mount actuator



SHOCK ABSORBERS **A****H** **S****H**

- Allows increased operating speed and load
- Self-compensates for load or speed changes
- Minimizes impact load to equipment
- Fixed or adjustable position shocks



SINGLE-END PORTING **S**

- Convenient single-end air connection



SWITCHES

- Largest number of sensing choices in the industry: Reed, Solid State PNP or NPN, all available normally open or normally closed
- Flush mount, drop-in installation, anytime
- Bright LEDs, power & signal indication
- CE rated, RoHS compliant

SPECIFICATIONS

		N INTERNAL BEARING			S SOLID BEARING			P PROFILED RAIL BEARING		
		MXP25N	MXP32N	MXP40N	MXP25S	MXP32S	MXP40S	MXP25P	MXP32P	MXP40P
Actual Bore Size	in	1.00	1.25	1.50	1.00	1.25	1.50	1.00	1.25	1.50
	mm	25	32	38	25	32	38	25	32	38
Base Weight	lb	1.70	3.58	5.57	2.30	4.68	7.64	2.94	5.89	9.91
	kg	0.77	1.62	2.53	1.04	2.12	3.47	1.33	2.67	4.50
Weight per unit of stroke	lb/in	0.134	0.233	0.306	0.134	0.233	0.306	0.192	0.316	0.491
	kg/mm	0.0024	0.0042	0.0055	0.0024	0.0042	0.0055	0.0034	0.0056	0.0088
Max Distance Between Tube Clamps (at Max Load)	in	22.6	27.0	27.4	17.5	19.6	20.7	8.9	12.2	13.5
	mm	574	686	696	445	498	527	225	309	343
Auxiliary Carrier; Min. "D" Between Carriers	in	6.00	7.00	8.50	6.00	7.00	8.50	6.00	7.00	8.50
	mm	152.4	177.8	215.9	152.4	177.8	215.9	152.4	177.8	215.9
Max Operating Pressure	PSI	100								
	bar	6.9								
Temperature Range	°F	20 to 140								
	°C	-7 to 60								

THEORETICAL FORCE VS PRESSURE

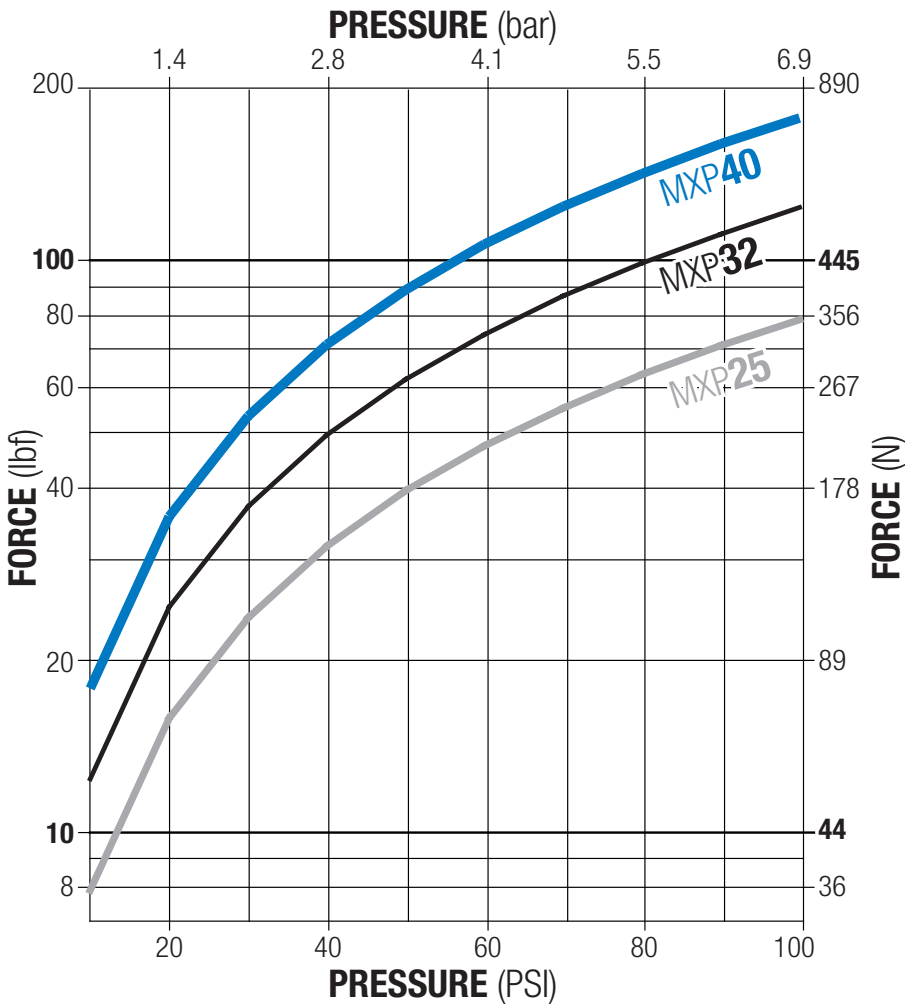

MOMENT AND LOAD CAPACITY

N INTERNAL BEARING

STANDARD



BORE			MAXIMUM BENDING MOMENTS			MAX. LOAD	THRUST (at 100 PSI)
			M _x	M _y	M _z	F _z	
2 5	Inch	1.00 in	9.0 in-lbs	132 in-lbs	27 in-lbs	65 lbf	78.5 lbf
	Metric	25 mm	1.0 N-m	14.9 N-m	3.1 N-m	289 N	349 N
3 2	Inch	1.25 in	36 in-lbs	318 in-lbs	120 in-lbs	115 lbf	123 lbf
	Metric	32 mm	4.1 N-m	35.9 N-m	13.6 N-m	512 N	546 N
4 0	Inch	1.50 in	55 in-lbs	575 in-lbs	156 in-lbs	195 lbf	177 lbf
	Metric	38 mm	6.2 N-m	65.0 N-m	17.6 N-m	867 N	786 N

S SOLID BEARING

STANDARD



BORE			MAXIMUM BENDING MOMENTS			MAX. LOAD	THRUST (at 100 PSI)
			M _x	M _y	M _z	F _z	
2 5	Inch	1.00 in	60 in-lbs	110 in-lbs	34 in-lbs	70 lbf	78.5 lbf
	Metric	25 mm	6.8 N-m	12.4 N-m	3.8 N-m	289 N	349 N
3 2	Inch	1.25 in	100 in-lbs	350 in-lbs	140 in-lbs	150 lbf	123 lbf
	Metric	32 mm	11.3 N-m	39.5 N-m	15.8 N-m	512 N	546 N
4 0	Inch	1.50 in	275 in-lbs	600 in-lbs	220 in-lbs	225 lbf	177 lbf
	Metric	38 mm	31.1 N-m	67.8 N-m	24.9 N-m	867 N	786 N

P PROFILED RAIL

STANDARD



BORE			MAXIMUM BENDING MOMENTS			MAX. LOAD		THRUST (at 100 PSI)
			M _x	M _y	M _z	F _y	F _z	
2 5	Inch	1.00 in	126 in-lbs	502 in-lbs	377 in-lbs	449 lbf	449 lbf	78.5 lbf
	Metric	25 mm	14.2 N-m	56.7 N-m	42.6 N-m	1,997 N	1,997 N	349 N
3 2	Inch	1.25 in	226 in-lbs	1,344 in-lbs	1,344 in-lbs	569 lbf	569 lbf	123 lbf
	Metric	32 mm	25.5 N-m	152 N-m	152 N-m	2,531 N	2,531 N	546 N
4 0	Inch	1.50 in	600 in-lbs	1,913 in-lbs	1,913 in-lbs	736 lbf	736 lbf	177 lbf
	Metric	38 mm	67.8 N-m	216 N-m	216 N-m	3,274 N	3,274 N	786 N

⚠ The above ratings are the maximum values for shock-free, vibration-free operation in a typical industrial environment, which must not be exceeded even in dynamic operation. Contact Tolomatic for assistance in selecting the most appropriate actuator for your application.

With combined loads, L_f must not exceed the value 1.

$$L_f = \frac{M_x}{M_{x_{max}}} + \frac{M_y}{M_{y_{max}}} + \frac{M_z}{M_{z_{max}}} + \frac{F_y}{F_{y_{max}}} + \frac{F_z}{F_{z_{max}}} \leq 1$$

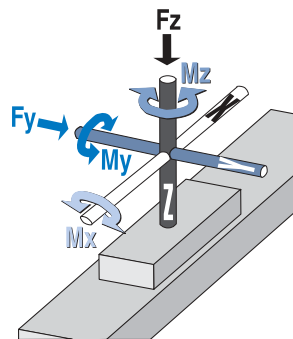

MOMENT AND LOAD CAPACITY

N INTERNAL BEARING

DW AUXILIARY CARRIER



BORE		"D" MIN		MAXIMUM BENDING MOMENTS*			MAX. LOAD		THRUST (at 100 PSI)
				MxA	MyA	MzA	FzA	FyA	
2 5	Inch	1.00 in	6.0 in	9.0 in-lbs	390 in-lbs	143 in-lbs	130 lbf	78.5 lbf	
	Metric	25 mm	152 mm	1.0 N-m	44.1 N-m	16.2 N-m	578 N	349 N	
3 2	Inch	1.25 in	7.0 in	36 in-lbs	805 in-lbs	302 in-lbs	230 lbs	123 lbf	
	Metric	32 mm	178 mm	4.1 N-m	91.0 N-m	34.1 N-m	1,023 N	546 N	
4 0	Inch	1.50 in	8.5 in	55 in-lbs	1,658 in-lbs	413 in-lbs	390 lbs	177 lbf	
	Metric	38 mm	216 mm	6.2 N-m	187 N-m	46.7 N-m	1,735 N	786 N	

*At minimum "D" distance see graph on opposite page for complete information

S SOLID BEARING

DW AUXILIARY CARRIER



BORE		"D" MIN		MAXIMUM BENDING MOMENTS*			MAX. LOAD		THRUST (at 100 PSI)
				MxA	MyA	MzA	FzA	FyA	
2 5	Inch	1.00 in	6.0 in	120 in-lbs	420 in-lbs	420 in-lbs	140 lbf	78.5 lbf	
	Metric	25 mm	152 mm	13.6 N-m	47.5 N-m	47.5 N-m	623 N	349 N	
3 2	Inch	1.25 in	7.0 in	200 in-lbs	1,050 in-lbs	1,050 in-lbs	300 lbf	123 lbf	
	Metric	32 mm	178 mm	22.6 N-m	119 N-m	119 N-m	1,335 N	546 N	
4 0	Inch	1.50 in	8.5 in	550 in-lbs	1,913 in-lbs	1,913 in-lbs	450 lbf	177 lbf	
	Metric	38 mm	216 mm	62.1 N-m	216 N-m	216 N-m	2,002 N	786 N	

*At minimum "D" distance see graph on opposite page for complete information

P PROFILED RAIL

DW AUXILIARY CARRIER



BORE		"D" MIN		MAXIMUM BENDING MOMENTS*			MAX. LOAD		THRUST (at 100 PSI)
				MxA	MyA	MzA	FzA	FyA	
2 5	Inch	1.00 in	6.0 in	252 in-lbs	1,613 in-lbs	1,613 in-lbs	898 lbf	898 lbf	78.5 lbf
	Metric	25 mm	152 mm	28.5 N-m	182 N-m	182 N-m	3,993 N	3,993 N	349 N
3 2	Inch	1.25 in	7.0 in	457 in-lbs	2,202 in-lbs	2,202 in-lbs	1,138 lbf	1,138 lbf	123 lbf
	Metric	32 mm	178 mm	51.6 N-m	249 N-m	249 N-m	5,063 N	5,063 N	546 N
4 0	Inch	1.50 in	8.5 in	1,200 in-lbs	3,601 in-lbs	3,601 in-lbs	1,472 lbf	1,472 lbf	177 lbf
	Metric	38 mm	216 mm	136 N-m	407 N-m	407 N-m	6,549 N	6,549 N	786 N

*At minimum "D" distance see graph on opposite page for complete information

⚠ The above ratings are the maximum values for shock-free, vibration-free operation in a typical industrial environment, which must not be exceeded even in dynamic operation. Contact Tolomatic for assistance in selecting the most appropriate actuator for your application.

With combined loads, L_f must not exceed the value 1.

$$L_f = \frac{M_x}{M_{x_{max}}} + \frac{M_y}{M_{y_{max}}} + \frac{M_z}{M_{z_{max}}} + \frac{F_y}{F_{y_{max}}} + \frac{F_z}{F_{z_{max}}} \leq 1$$

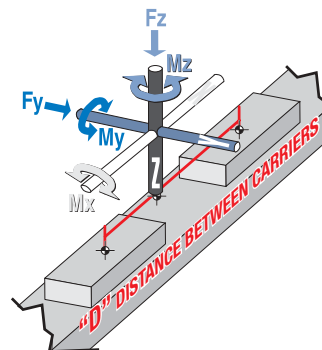

AUXILIARY CARRIER BENDING MOMENTS

N INTERNAL BEARING

(MyA & MzA) vs. DISTANCE

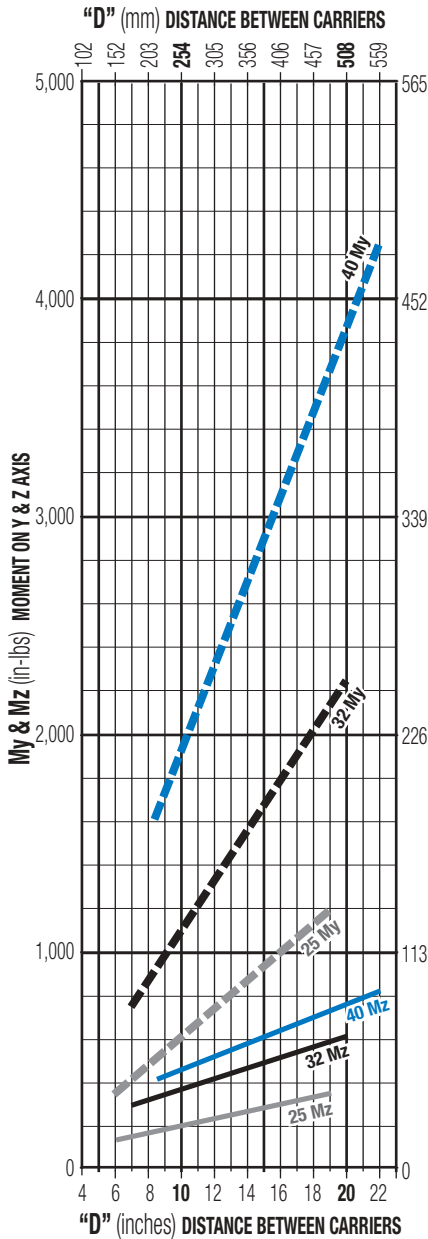

S SOLID BEARING

(MyA & MzA) vs. DISTANCE

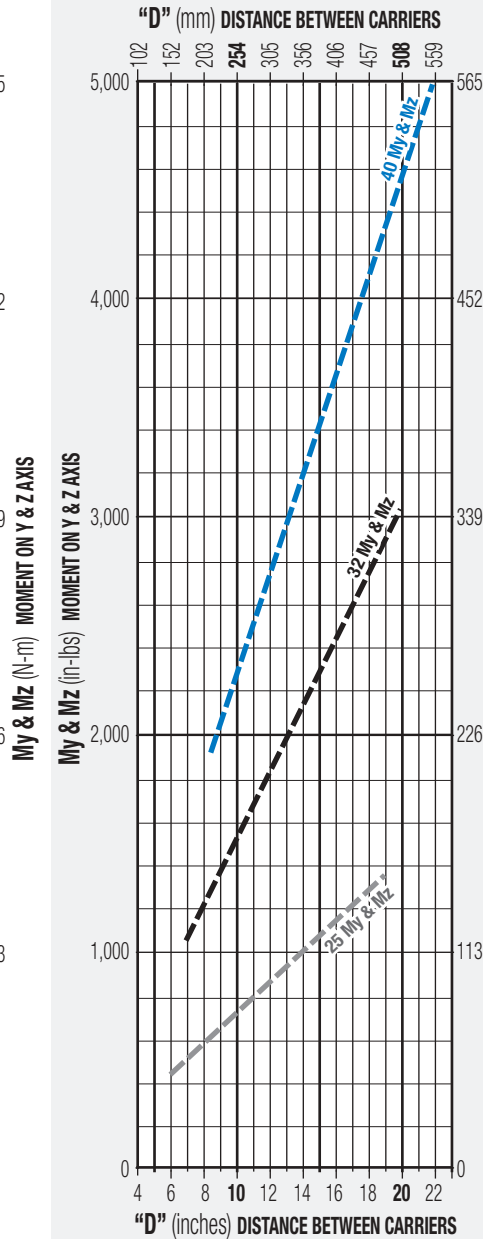

P PROFILED RAIL

(MyA & MzA) vs. DISTANCE

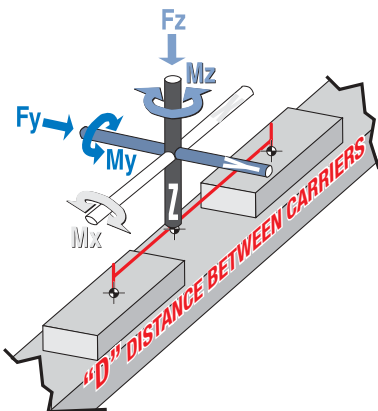
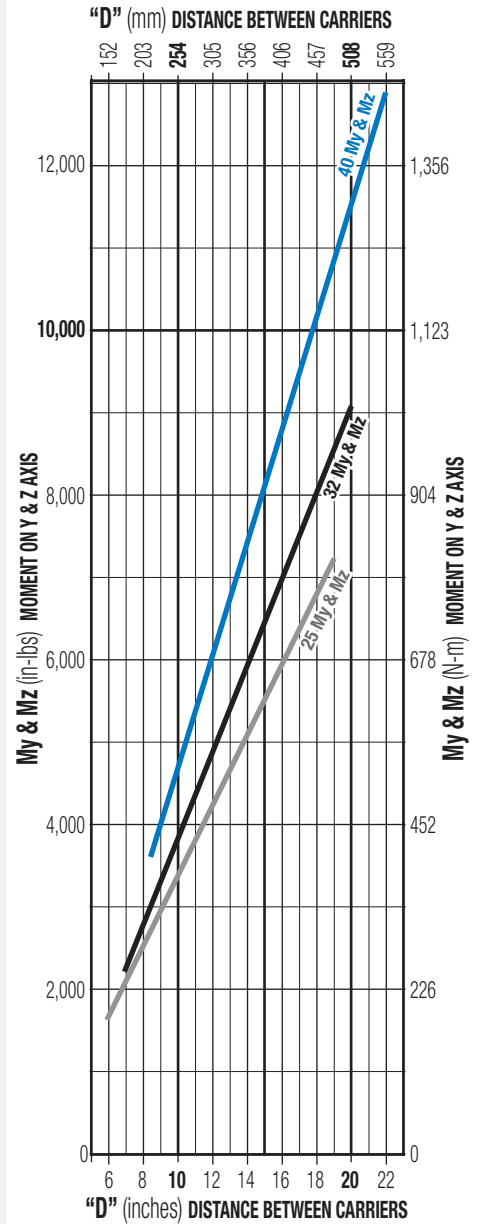

Ratings were calculated with the following conditions:

- 1.) Coupling between carriers is rigid.
- 2.) Load is equally distributed between carriers.
- 3.) Coupling device applies no misalignment loads to carriers.

SWITCHES

SPECIFICATIONS



MX products offer a large number of sensing choices. There are 12 switch choices: reed, solid state PNP (sourcing) or solid state NPN (sinking); in normally open or normally closed; with flying leads or quick-disconnects.

Commonly used for end-of-stroke positioning, these switches allow drop-in installation anywhere along the entire actuator length. The one piece design includes the retained fastening hardware and is designed for any open side or bottom slot on the MX. The internal piston magnet is a standard feature, therefore these switches can be installed in the field at anytime.

Switches are used to send analog signals to PLC (programmable logic controller), TLL, CMOS circuit or other controller device. Switches contain reverse polarity protection. Solid state QD cables are shielded; shield should be terminated at flying lead end.

All switches are CE rated and are RoHS compliant. Switches feature bright red or yellow LED signal indicators; solid state switches also have green LED power indicators.

MODELS

Order Code	Part Number	Normally	Sensor Type	Lead		Power LED	Signal LED
RY	8100-9082	Open	Reed	5m		—	Red
RK	8100-9083*	Open	Reed	Quick-disconnect		—	Red
NY	8100-9084	Closed	Reed	5m		—	Yellow
NK	8100-9085*	Closed	Reed	Quick-disconnect		—	Yellow
TY	8100-9088	Open	Solid State PNP	5m		Green	Yellow
TK	8100-9089*	Open	Solid State PNP	Quick-disconnect		Green	Yellow
KY	8100-9090	Open	Solid State NPN	5m		Green	Red
KK	8100-9091*	Open	Solid State NPN	Quick-disconnect		Green	Red
PY	8100-9092	Closed	Solid State PNP	5 m		Green	Yellow
PK	8100-9093*	Closed	Solid State PNP	Quick-disconnect		Green	Yellow
HY	8100-9094	Closed	Solid State NPN	5m		Green	Red
HK	8100-9095*	Closed	Solid State NPN	Quick-disconnect		Green	Red

*Quick-disconnect switches ordered by part number do not include female QD socket with 5m cable - order #8100-9080

ORDERING

MODEL SELECTION (MUST BE IN THIS ORDER)

MXP40PSN SM2007-02

OPTIONS (IN ANY ORDER)

DW215-9 FM2 TC8 TK2 AH2

MODEL

MX MX Pneumatic Band Cylinder

BORE

16* 16 mm ($\frac{5}{8}$ -inch) bore
25 25 mm (1-inch) bore
32 32 mm (1 $\frac{1}{4}$ -inch) bore
40 38 mm (1 $\frac{1}{2}$ -inch) bore
50* 51 mm (2-inch) bore
63* 64 mm (2 $\frac{1}{2}$ -inch) bore

** 16, 50 & 63 bore sizes available soon*

BEARING

N Internal Bearing
S Solid Bearing
P Profiled Rail

PORTING

TP Metric Taper, (Rc/BST) Dual-end
GP Metric Parallel, (ISO-G/BSP) Dual-end
NP NPT, Dual-end
ST Single-end, Metric Taper
SG Single-end, Metric Parallel
SN Single-end, NPT

STROKE LENGTH & MOUNTING TYPE

SK _____ Stroke, enter desired stroke length in **inches**
SM _____ Stroke, enter desired stroke length in **millimeters**

NOTE: Actuator mounting threads and mounting fasteners will be either inch or metric; depending on how stroke length is indicated

SK=inch mounting
SM= metric mounting

AUXILIARY CARRIER

DW _____ Auxiliary Carrier, enter center-to-center spacing desired in **inches** (SK) or **millimeters** (SM)

(Same unit of measure as stroke length is required)

▲ Center-to-center spacing between carriers adds to overall length of the actuator, this distance will not be subtracted from stroke length specified in the previous step

MOUNTING

FM Foot Mount, enter quantity desired
TC Tube Clamps, enter number of pairs
FL Floating Mount

▲ NOTE: Floating Mount is not available with "P" Profiled Rail
▲ NOTE: Shock Absorbers are not available with Floating Mount

SWITCHES

RY Reed Switch (Normally Open) with 5-meter lead, & enter quantity desired
RK Reed Switch (Normally Open) with 5-meter lead/QD, & quantity
NY Reed Switch (Normally Closed) with 5-meter lead, & quantity
NK Reed Switch (Normally Closed) with 5-meter lead/QD, & quantity

TY Solid State Switch PNP (Normally Open) w/ 5-meter lead, & quantity
TK Solid State Switch PNP (Normally Open) w/ 5-meter lead/QD, & quantity
KY Solid State Switch NPN (Normally Open) w/ 5-meter lead, & quantity
KK Solid State Switch NPN (Normally Open) w/ 5-meter lead/QD, & quantity

PY Solid State Switch PNP (Normally Closed) w/ 5-meter lead, & quantity
PK Solid State Switch PNP (Normally Closed) w/ 5-meter lead/QD, & quantity
HY Solid State Switch NPN (Normally Closed) w/ 5-meter lead, & quantity
HK Solid State Switch NPN (Normally Closed) w/ 5-meter lead/QD, & quantity

SHOCK ABSORBER

AD Adjustable Shock Hardware & enter quantity desired
AL Adjustable Shock Light Duty & enter quantity desired
AH Adjustable Shock Heavy Duty & enter quantity desired

SD Fixed Shock Hardware & enter quantity desired
SL Fixed Shock Light Duty & enter quantity desired
SH Fixed Shock Heavy Duty & enter quantity desired

▲ NOTE: Floating Mount is not available with Shock Absorbers

VISIT www.tolomatic.com/mxp FOR COMPLETE, UP-TO-DATE INFORMATION

▲ Not all codes listed are compatible with all options.

Call Tolomatic to determine available options and accessories based on your application requirements.

THE TOLOMATIC DIFFERENCE What you expect from the industry leader:



EXCELLENT TECHNICAL SUPPORT

Our people make the difference! Expect prompt, courteous replies to all of your application and product questions.



2D DRAWINGS & 3D MODELS AVAILABLE ON THE WEB

Easy to access CAD files are available in many popular formats.



SIZING & SELECTION SOFTWARE

Windows® compatible, downloadable from our website – FREE – the best tool of its kind on the market! Product selection has never been easier.



INDUSTRY LEADING DELIVERIES

Standard catalog products are built to order and ready-to-ship in 5 days or less. Modified and custom products ship weeks ahead of the competition.



CUSTOM PRODUCTS

From standard catalog products... to modified products... to completely unique custom products, Tolomatic designs and builds the best solutions for your challenging applications.

ALSO CONSIDER THESE OTHER TOLOMATIC PRODUCTS:

ELECTRIC PRODUCTS



Rod & Guided Rod Style Actuators, Screw & Belt Drive Rodless Actuators, High Thrust Actuators, Motors, Axiom Drives/Controllers

BROCHURE #9900-9074 ENDURANCE TECHNOLOGY BROCHURE #9900-4016 CATALOG #3600-4609 www.tolomatic.com/electric

PNEUMATIC PRODUCTS



RODLESS CYLINDERS: Band Cylinders, Cable Cylinders, Magnetically Coupled Cylinders/Slides; Guided Rod Cylinder Slides

BROCHURE #9900-9075 BAND CYLINDER BROCHURE #9900-4015 CATALOG #9900-4000 www.tolomatic.com/pneumatic

POWER TRANSMISSION PRODUCTS



GEARBOXES: Float-A-Shaft™, Slide-Rite™; Disc Cone Clutch; Caliper Disc Brake

BROCHURE #9900-9076 CATALOG #9900-4009 www.tolomatic.com/pt



3800 County Road 116 • Hamel, MN 55340 U.S.A.

Phone: (763) 478-8000 • Fax: (763) 478-8080

Toll-Free: **1-800-328-2174**

Email: help@tolomatic.com • <http://www.tolomatic.com>

THK and Caged Ball are registered trademarks of THK Co. Ltd.; www.thk.com. All brand and product names are trademarks or registered trademarks of their respective owners. Information in this document is believed accurate at time of printing. However, Tolomatic assumes no responsibility for its use or for any errors that may appear in this document. Tolomatic reserves the right to change the design or operation of the equipment described herein and any associated motion products without notice. Information in this document is subject to change without notice.

Visit www.tolomatic.com for the most up-to-date technical information

